

For Air, N₂, Ar, CO₂/PFM

P. 899

Measurement flow range ℓ/min				
	Integrated type	Remote type		
		Sensor unit	Display unit	
	0.2 to 10 (0.2 to 5)	PFM710	PFM510	PFM3□□
	0.5 to 25 (0.5 to 12.5)	PFM725	PFM525	
1 to 50 (1 to 25)	PFM750	PFM550		
2 to 100 (2 to 50)	PFM711	PFM511		

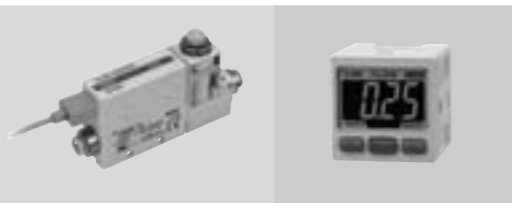

For Air, N₂/PFMV

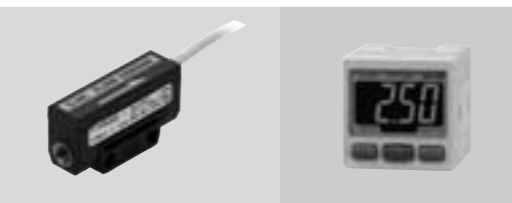
P. 947

Measurement flow range ℓ/min			
	Remote type		
	Sensor unit	Display unit	
	0.0 to 0.5	PFMV505	PFMV30□
	0 to 1	PFMV510	
	0 to 3	PFMV530	
	-0.5 to 0.5	PFMV505F	
-1 to 1	PFMV510F		
-3 to 3	PFMV530F		



For Air, N₂/PF2A

P. 974

Measurement flow range ℓ/min							
	Integrated type	Remote type					
		Sensor unit	Display unit	4-channel flow monitor			
	1 to 10	PF2A710	PF2A510	PF2A30□	PF2A20□		
	5 to 50	PF2A750	PF2A550				
	10 to 100	PF2A711	PF2A511				
	20 to 200	PF2A721	PF2A521	PF2A31□			
	50 to 500	PF2A751	PF2A551				
	150 to 3000	PF2A703H					
	300 to 6000	PF2A706H					
600 to 12000	PF2A712H						

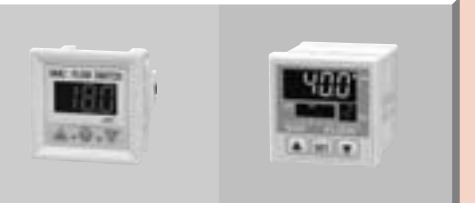

For Water/PF2W

P. 988

Measurement flow range ℓ/min							
	Integrated type	Remote type					
		Sensor unit	Display unit	4-channel flow monitor			
	0.5 to 4	PF2W704(T)	PF2W504(T)	PF2W30□	PF2W20□		
	2 to 16	PF2W720(T)	PF2W520(T)				
5 to 40	PF2W740(T)	PF2W540(T)					
10 to 100	PF2W711	PF2W511	PF2W33□				

For Deionized Water and Chemicals/PF2D



P. 1015

Measurement flow range ℓ/min						
	Remote type					
	Sensor unit	Display unit	4-channel flow monitor			
	0.4 to 4	PF2D504	PF2D30□	PF2D20□		
	1.8 to 20	PF2D520				
4.0 to 40	PF2D540					

For Air/IFW5/IF3

Diaphragm style
P. 1034

Paddle style
P. 1040

Measurement flow range ℓ/min					
	Integrated type		Integrated type		
		Sensor unit	Display unit		
	1 to 10	IFW510		IF3□0	
10 to 20	IFW520		IF3□1		
20 to 50	IFW550		IF3□3		